

---

## Controlling a Packaging Line

---

Application Info: 012 [10.2005]

---

To ensure continuous flow production on a packaging line it is important to use a stop/start system that will run smoothly and require minimum maintenance.

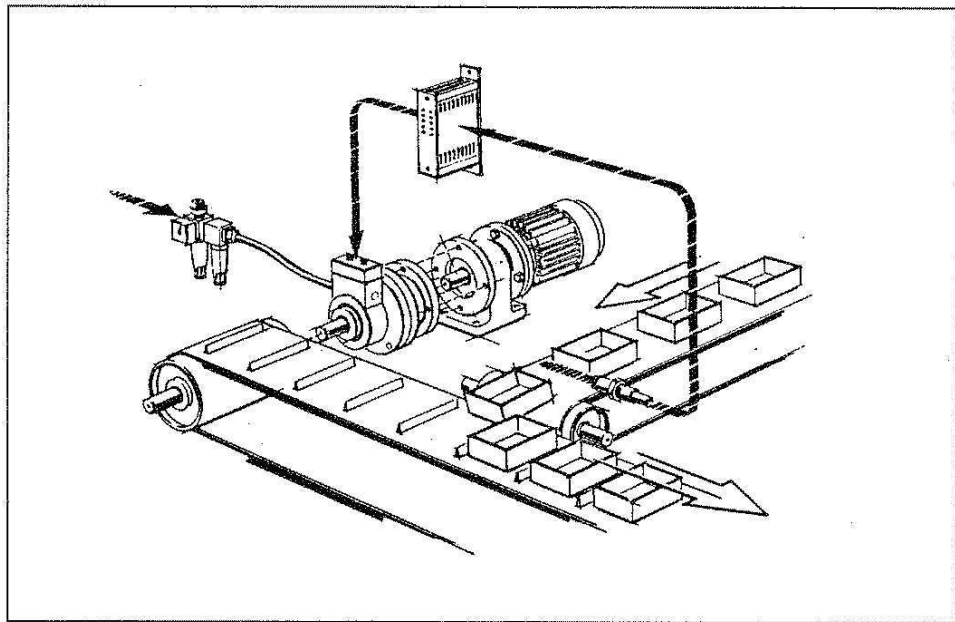

In this application the Rotastep starts and stops a conveyor belt on a packaging line. When a photocell registers “package missing” from the feed belt, the Rotastep is brought to a stop. It is held in this position until packages are again registered on the feed belt by the photocell.

---

### Advantages

- Long service life.
  - Maintenance-free service life. I.e. No adjustments required throughout the service life.
-